

## MVCT Megger VT & CT Analyzer



- **Ability to test both VT and CT**
- **Easy to use one-button automated test plans**
- **Industry leading test duration using patented simultaneous tap measurements**
- **Smallest and lightest unit on the market**
- **CT kneepoints up to 30 kV**
- **CT grouped testing includes demagnetization, knee points, ratios, saturation curves, winding resistances, polarities and phase deviation (on all taps of multi-ratio CTs)**
- **VT testing including demagnetization, ratio, winding resistance, polarity and phase deviation**
- **Performs secondary burden tests**
- **Integrated 1 kV DC insulation test system**

### DESCRIPTION

The Megger MVCT test set is a lightweight, robust, portable unit capable of testing both current and voltage transformers. At less than 20 lb (10Kg) the MVCT is a highly portable unit that also offers accuracy in testing. Capable of performing saturation, ratio, polarity, winding resistance, and insulation tests on current transformers, the MVCT can also be used for testing metering and protection class voltage/potential transformers. The MVCT provides a microprocessor controlled variable voltage and current output along with precision instrumentation for automatically testing single and multi-ratio CTs and VT's. The MVCT makes testing CTs easy. It will directly connect to multi ratio CT's and perform all tests – saturation, ratio and polarity, winding resistance, and insulation – on all taps with the push of a button and without changing leads. This greatly reduces testing time. The MVCT can be controlled via its large, full color, high resolution, sunlight readable TFT LCD touch screen display. This interface allows the user to perform manual and automatic testing quickly and easily using the manual test screen, or by using pre-constructed test routines. The large color display also permits the user to easily read all pertinent data while the test is being performed and provides the ability to view the results when the test is complete. The unit can also be configured to come without a display and thus be controlled via a laptop utilizing PowerDB or with Megger's existing Smart Touch View Interface™(STVI).

Both current transformers and voltage transformers can be tested in their equipment configuration, such as being mounted in transformers, oil circuit breakers or switchgear. It is necessary for the equipment to be completely isolated from the electrical system

### APPLICATIONS

#### CT TESTING

##### Saturation test

With the single push of a button, the MVCT performs a CT saturation test and calculates the rated knee point. The saturation test can test kneepoints up to 30 kV using an new innovative DC technique. This allows testing even the larger generation class CT with a portable instrument.

The MVCT will calculate the rated knee point in compliance with either IEEE C57.13.1, IEC 60044-1, IEC 60044-6 or IEC 61869 on both standards as well as of specialized CTs such as PX, TPS, TPX, and TPY. While the saturation test is being performed, the MVCT will plot the CT saturation curve on the STVI display and automatically provide the user with the rated knee point per the desired IEEE or IEC standard. Many substations CTs include a multi-ratio secondary; therefore the MVCT has the ability to plot and simultaneously display up to 10 CT saturation curves.

##### Ratio, polarity (and burden) test

Ratio testing is performed by comparing a voltage applied to the secondary winding to the resulting voltage produced on the primary winding. Polarity of the current transformer under test is indicated to the operator by a simple "Correct" or "Incorrect" indication on the display accompanied by the measured phase angle.

##### Winding resistance test

Measures CT winding resistance with the injection of a test current, measuring the DC voltage and calculating temperature compensated resistance. The MVCT will automatically remind and give the user the option to demagnetize the CT after a test.

## Demagnetization

Normal operating conditions and typical winding resistance measurements can cause a CT to become magnetized. The MVCT offers the ability to automatically demagnetize the CT under test or manually demagnetize the CT at any time. Prior to testing demagnetization is recommended per ANSI C57.13.1. This demagnetization routine ensures that the CT testing yields accurate results

## CT burden

The MVCT measures the connected CT burden load with direct injection of secondary current to a load that is disconnected from the CT. The MVCT measures the Secondary voltage in magnitude and angle and reports the connected burden in VA and power factor.

## INDUCTIVE VT TESTING

### Ratio, polarity and ratio with burden test

As part of a regular maintenance program to verify factory readings and locate the presence of defects in voltage transformers, the MVCT can accurately measure the ratio, phase displacement, and secondary winding resistance. The MVCT utilizes up to 300 V to accurately measure the ratio, phase angle of a VT

### Winding resistance test

Measures VT secondary winding resistance with the injection of a test current, measuring the DC voltage and calculating temperature compensated resistance.

### Excitation Characteristics and Short Circuit Impedance

The MVCT system includes the capability to measure both excitation characteristics and winding impedances. The data in conjunction with other test data is used to calculate losses of the VT and predict how the VT will perform at rated voltages.

### Data storage and printing

The MVCT test system not only permits accurate and automated VT & CT testing, but also catalogues and stores test results within the instrument for simple retrieval by software at a later date. All catalogued test results can be uploaded to Megger's PowerDB™ Lite for report generation and saturation curve plotting on a computer or STVI. PowerDB Lite also has the ability to operate the MVCT with no operator intervention, thus providing a completely computer controlled automated test system.

Onboard memory allows complete test results and data to be stored in one complete file, permitting easy access and quick construction of reports such as saturation curves with knee point and ratios.

## FEATURES AND BENEFITS

- **Direct connection to multi-ratio CT's** - The MVCT will directly connect to all taps on multi-ratio CT's to eliminate lead changes required to test all inner-winding CT ratios, saturation curves and knee points. The MVCT will test all programmed taps with the push of one button.
- **Full color, high resolution, sunlight readable TFT LCD touch screen** - Menu screens and touch screen function buttons are provided to quickly and easily select the desired test function. Tests results can be saved to the unit for download to a memory stick to transfer or print test reports.
- **CT saturation, ratio and polarity, winding resistance, and insulation automated testing** - The microprocessor-controlled output fully automates testing of CT's. This automated testing simplifies CT testing and reduces testing time. Automated testing is accomplished directly on the MVCT or via PowerDB Lite.
- **VT ratio and polarity, secondary winding resistance** - The MVCT offers complete testing of VT's. The MVCT simplifies VT testing and reduces testing time.
- **CT demagnetization** - During operation and routine DC winding resistance testing, it is possible for a CT to become magnetized. The MVCT includes an automated CT demagnetization function, which allows determination of accurate Knee Point and ratios thus providing stable, repeatable test results, and reduces test time.
- **Insulation test** - The MVCT includes a 500/1000V insulation test system to verify the VT & CT secondary winding and secondary wiring. This insures that the secondary insulation has not degraded and will continue to perform its function during high current faults.
- **Concurrent measurement** - The MVCT system can provide concurrent measurement of voltages on all taps during CT saturation, and ratio and polarity testing. This allows the MVCT system to calculate the knee points, and ratios of all windings at the same time thus eliminating the need for multiple tests on a CT. This will drastically reduce testing time. All tests are performed in compliance with IEEE C57.13.1 test guidelines.
- **Test result report** - The MVCT offers storage of complete test files in an easy-to-use, versatile format that permits upload to PowerDB Lite, or printing test results using the optional external printer. These options provide a simple, complete, easy way to store over 1000 test results and saturation curves. All test results can be catalogued and stored in the MVCT.

## TECHNICAL FEATURES

- Automatic testing according to ANSI C57.13; IEC 60044-1; IEC 60044-6; or IEC 61869-2 on Relaying/Protection Class CTs., and IEC 61869-3 on inductive voltage transformers
- Excellent noise immunity from energized power lines in substations
- **CT ratio and phase measurement with consideration of nominal and connected burdens**
  - Primary currents from 1% to 200% of the rated value
  - Various burdens of 1/8, 1/4, 1/2, and full
- Ratio accuracy to  $\pm 0.05\%$
- CT & VT winding resistance measurement
- Automatic demagnetization of CT after test
- Decoupled demagnetization routine that can be performed at any time
- Reduced Testing time with concurrent measurement of multi ratio CTs
- Small and lightweight ( < 20lb / 9.07kg )
- Increased level of safety using low voltage DC methods
- Remote control interface
- Easily configurable test plans
- Customizable reports
- CT knee point voltages up to 30 kV

## SPECIFICATIONS

<b>Input</b>	100 to 265 V, 50 or 60 Hz, 10 A max.	
<b>Outputs</b>	Output Voltage	0 to 300 V AC 0 to 300 V DC
	Output Current	0 to 1 A eff
	Output Power	300 VA
<b>Inputs</b>	Ranges	0 to 2/10/50/300 V
	Resolution	0.0001 V
	Accuracy	$\pm 0.02\%$ of reading and $\pm .02\%$ range typical $\pm 0.05\%$ of reading and $\pm 0.05\%$ range maximum
	Current Measurement	
	Range	0 to 1.0 A
	Resolution	0.0001 A
	Accuracy	$\pm 0.08\%$ of reading $\pm 0.08\%$ range typical $\pm 0.2\%$ of reading $\pm 0.2\%$ range maximum

## CT TESTING

### Ratio

Standard option range	Accuracy
0.8 to 2000	$\pm 0.02\%$ typical $\pm 0.05\%$ maximum.
2000 to 5000	$\pm 0.03\%$ typical $\pm 0.1\%$ maximum.
5000 to 20000	$\pm 0.05\%$ typical $\pm 0.2\%$ maximum.

### Phase angle

3 digits	
<b>Range</b>	0 to 360 degrees
<b>Resolution</b>	1 min
<b>Accuracy</b>	$\pm 3$ min typical $\pm 6$ maximum

## Winding resistance test

<b>Measuring range</b>	0-30 $\Omega$
<b>Accuracy</b>	(at 20°C) 0.5% $\pm 3$ m $\Omega$ (typical) / 1% $\pm 10$ m $\Omega$ (guaranteed) (0 – 30 $\Omega$ )

## Insulation test

<b>Test voltage</b>	1000 VDC, 500 VDC
<b>Measuring range</b>	20 G $\Omega$
<b>Short circuit current</b>	1.5 mA nominal
<b>Test current on load</b>	1 mA at min. pass values of insulation (as specified in BS7671, HD 384 and IEC 364)
<b>Accuracy</b>	1000 volts $\pm 3\% \pm 2$ digits $\pm 0.2\%$ per G $\Omega$ 500 volts $\pm 3\% \pm 2$ digits $\pm 0.4\%$ per G $\Omega$

## Communication interfaces

Ethernet  
USB

## Environment

<b>Operating</b>	-10° C to 50° C
<b>Storage</b>	-30° C to 70° C

## Enclosure

The unit is housed in a rugged enclosure suitable for use in outdoor substations.

## Standards

IEC 61010  
CSA 22.2  
CE conformity

## Dimensions

14" H X 7.5" W X 12" D  
(36 H cm X 19.3 W cm X 30.5 D cm)

## Weight

20 lb (9.07 kg)

## DESCRIPTIONS OF HARDWARE OPTIONS AND ACCESSORIES

### VOLTAGE TRANSFORMER (VT) TESTING OPTION

#### DESCRIPTION

The **MVCT** can be configured to include the functionality to test voltage transformers. With the basic configuration the **MVCT** can measure ratio errors and phase angles as well as the secondary winding resistance. If more information is needed the **MVCT** can be configured with the advanced testing option that will additionally determine the excitation characteristics, and the impedance of inductive voltage transformers.

#### APPLICATIONS

As part of a regular maintenance program to verify factory readings and locate the presence of defects in voltage transformers, the **MVCT** can accurately measure the ratio, phase displacement, secondary winding resistance, excitation characteristics, and impedance. The **MVCT** utilizes up to 300v to accurately measure the ration and phase angle of inductive voltage transformers.

### VT OPTION SPECIFICATIONS

#### Inductive VT testing

<b>Outputs</b>	Output Voltage	0 to 300 V AC
	Output Current	0 to 1 A eff
	Output Power	300 VA

#### Ratio measurement

Voltage Ratio	Voltage Level	Accuracy
1 to 350	.6 kV to 35 kV	±0.03% typical ±0.2% maximum,
350 to 1100	35 kV to 110 kV	±0.05% typical ±0.3% maximum,
1100 to 2450	110 kV to 245 kV	±0.05% typical ±0.5% maximum.

#### Phase angle measurement

Voltage ratio	Voltage Level	Accuracy
1 to 350	.6 kV to 35 kV	±3 min typical ±6 min maximum,
350 to 1100	35 kV to 110 kV	±3 min typical ±6 min maximum
1100 to 2450	110 kV to 245 kV	±3 min typical ±6 min maximum.

#### Winding resistance measurement

<b>Resolution</b>	1m Ω
<b>Guaranteed accuracy</b>	(at 20° C) ±0.5% + 1 mΩ

#### Insulation test

<b>Test voltage</b>	1000 VDC, 500 VDC
<b>Measuring range:</b>	20 GΩ
<b>Short circuit current:</b>	1.5 mA nominal
<b>Test current on load:</b>	1 mA at min. pass values of insulation (as specified in BS7671, HD 384 and IEC 364)

<b>Accuracy:</b>	1000 volts ±3% ±2 digits ±0.2% per GΩ 500 volts ±3% ±2 digits ±0.4% per GΩ
------------------	---

## RELAY TESTING OPTION

### DESCRIPTION

The MVCT can be configured to include the functionality to test electromechanical, solid-state and microprocessor based over-current relays, including voltage controlled, voltage restraint and directional over-current; test under/over voltage, single-phase impedance, single-phase power, directional, synchronizing, auto-synchronizing, negative sequence under/over voltage, current balance, frequency, volts/hertz, reclosing, thermal and various other relays

### APPLICATIONS

The current channel is rated for 30 amps @ 200 VA continuous, up to 60 amps @ 300 VA for short durations. It has a unique flat power curve from 4 to 30 amps that insures maximum compliance voltage to load at all times. With a high compliance voltage of 50 volts the SMRT1 has the capability to test high impedance over-current relays. The voltage channel can provide a variable output of 0- 30/150/300 Volts at 150 VA of output power, and has a unique flat power curve from 30 to 150 volts insuring maximum output power to the load at all times. With the voltage channel converted to current, it can perform minimum operating point, slope and timing on current differential relays, including harmonic restraint transformer differential relays (which can be tested one phase at a time).

### RELAY OPTION SPECIFICATIONS

<b>Outputs</b>	All outputs are independent from sudden changes in line voltage and frequency. This provides stable outputs not affected by sudden changes in the power source. All outputs are regulated so changes in load impedance do not affect the output.
----------------	--

<b>Output current</b>	Output power ratings are specified in AC rms values and peak power ratings. Output Current Power 1 ampere 15 VA 15.0 V rms continuous
-----------------------	---

<b>Output current power</b>	1 ampere 15 VA 15.0 V rms continuous
-----------------------------	--------------------------------------

<b>Max V / duty cycle</b>	4 amperes 200 VA (282 peak)
	50.0 V rms continuous
	15 amperes 200 VA (282 peak)
	13.4 V rms continuous
	30 amperes 200 VA (282 peak)
	6.67 V rms continuous
	75 amperes 300 VA (424 peak)
	5.00 V rms 90 cycles

#### DC 200 Watts

<b>AC voltage output</b>	<b>Outputs are rated with the following ranges:</b> Output volts power max I 30 volts 150 VA 5 amps 150 volts 150 VA (see Power V) 300 volts 150 VA 0.5 amps DC 150 watts Duty Cycle: Continuous
--------------------------	--

**Metering** Measured output quantities such as AC amperes, AC Volts, DC volts or DC amperes, and time may be simultaneously displayed on the large, color TFT LCD, optional STVI touch screen. The AC and DC outputs display the approximate voltage/current output prior to initiation of the outputs.

### AC voltage amplitude

**Accuracy**  $\pm 0.05\%$  reading + 0.02% range typical,  
 $\pm 0.15\%$  reading + 0.05% range maximum

**Resolution** .01

**Measurements** AC RMS

**Ranges** 30, 150, 300 V

### AC current amplitude

**Accuracy**  $\pm 0.05\%$  reading + 0.02% range typical,  
 $\pm 0.15\%$  reading + 0.05% range maximum

**Resolution** .001/.01

**Measurements** AC RMS

**Ranges** 30, 60 A

### DC voltage amplitude

**Accuracy** 0.1% range typical, 0.25% range maximum

**Resolution** .01

**Measurements** RMS

**Ranges** 30, 150, 300 V

### DC current amplitude

**Accuracy**  $\pm 0.05\%$  reading + 0.02% range typical,  
 $\pm 0.15\%$  reading + 0.05% range maximum

**Resolution** .001/.01

**Measurements** RMS

**Ranges** 30 A

## ORDERING INFORMATION

### Style Number Identification

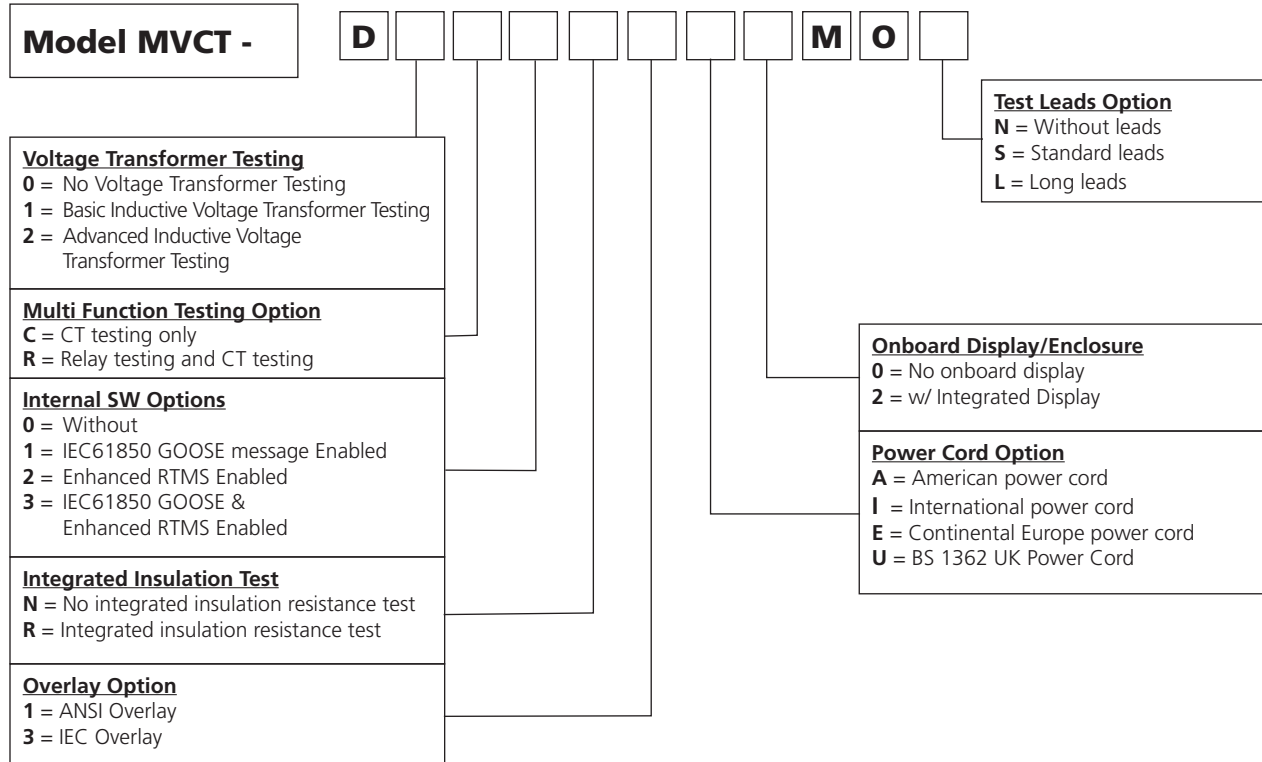

## DESCRIPTIONS OF HARDWARE OPTIONS

### Voltage Transformer Testing

Customers can choose which type of Voltage Transformer testing functionality they want the MVCT unit to have enabled. Customers should select letter **0** if they wish for the MVCT to not be configured for testing any type of voltage transformer. **1** should be selected if the customer wishes for the MVCT to be configured for performing basic tests on inductive voltage transformers. These basic tests include ratio and phase angle error accompanied with secondary winding resistance. The customer should select **2** if they desire the MVCT to be configured to perform the basic tests on both Inductive VTs and Capacitive VTs. The MVCT can also be configured to perform additional advanced tests on voltage transformers. In addition to the ratio, phase angle error, and winding resistance, the advanced option enables performing the excitation test, short circuit impedance, and insulation test.

### Multi Function Testing Option

Customers can select whether or not the MVCT has the capability to test single phase relays. If they want the unit to only test CT, customers should select the letter **C**, but if they wish for the MVCT to be configured to test both CT and single phase relays then the letter **R** should be selected.

### Internal SW Options

If the MVCT is configured to test relays, Megger GOOSE Configurator software may be used in the testing or commissioning of IEC 61850 compliant devices. In order for the MVCT to be able to subscribe as well as publish GOOSE messages, the MVCT must be configured to test relays and the IEC 61850 feature needs to be enabled. Enter the number **1** for the unit to come with the IEC61850 option enabled. Enter **2** to enable the enhanced RTMS software features such as the Synchronizer and Frequency test. Enter the number **3** to have both IEC 61850 gose massaging and the enhanced RTMS software features enabled. Enter 0 for the unit without IEC 61850 enabled.

### Integrated Insulation Test

Enter **R** for the unit to come with an integrated insulation resistance test capability. Enter **N** for the unit without an integrated insulation test.

### Power Cord Option

Customers can choose which type of power cord they want the unit to come with.

**A option** – NEMA 5-15 to IEC60310 C13 connectors, UL & CSA approved for countries with NEMA outlets.

**I option** – International color coded wires (light blue, brown and green with yellow stripe) insulation jacket stripped ready for male connector with IEC 60320 C13 connector. CE marked.

**E option** – CEE 7/7 Schuko plug to IEC 60320 C13 connector. CE marked.

**U option** – United Kingdom power cord with IEC 60320 C13 connector, and 13 amp fuse. CE marked.

### Test leads option

Enter the letter **N** for the unit without test leads. Enter the letter **S** for the unit to come with set of standard test leads. Enter the letter **L** for the unit to come with long set test leads.

### Test Leads and Accessories

All units come with a power cord (see power cord option), and Ethernet communication cable, and instruction manual CD. All other accessories vary depending on the options selected, see table of optional accessories

## TEST LEADS AND ACCESSORIES

All units come with a power cord, an Ethernet communication cable, and instruction manual. All other accessories varies depending on the features selected, see table of accessories.

### Included standard accessories

Description	Part Number
Power Cord - Depending on the style number, the unit will come with one of the following,	
Line cord, North American	620000
Line cord, continental Europe with CEE 7/7 Schuko Plug	50425
Line cord, international color coded wire	15065
Line cord, United Kingdom	90002-989
Ethernet cable for interconnection to PC, 210cm (7 ft.) long (Qty. 1 ea)	90003-594
Instruction manual	86027

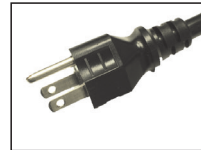

620000



50425



90002-989

### TABLE OF ACCESSORIES

Accessories are supplied with the selection of the various features depending upon the option selected. Test leads and accessories can also be ordered individually, see below for accessories included with option and part numbers.

### STANDARD LEADS

Accessories included in standard set of test leads.



**90001-165**  
**Accessory carry case (1 each)**

Used to carry power cord, Ethernet cable, and test leads



**1009-322**  
**Set of primary test leads (1 each)**

( X1, X2, X3, X4, X5 ) test leads  
20ft ( 6.096m)



**1009-515**  
**Set of secondary test leads (1 each)**

H1, H2 test leads  
40 ft ( 12,18m)



**2003-724**  
**Ground lead (1 each)**

green with yellow, with large ground clip, 20 ft



**90004-427**  
**Alligator clip (5 each)**

Black, 4 mm



**684004**  
**Cable/Spade lug adapter (small, 5 each)**

Small lug fit most new relay small terminal blocks. Lug adapter, red, 4.1 mm, rated up to 1000 V/ 20 Amps CAT II



**684003**  
**Cable/Spade lug adapter (small, 5 each)**

Large lug fits most relay terminal blocks  
Lug adapter 6.2 mm rated to 1000 V/20 A CAT II



**90004-599**  
**Screw in banana test jack (5 each)**



**684005**  
Lug adapter, **black**, 4.1 mm, rated up to 1000 V/ 20 Amps CAT II.



**2001-53**  
Jumper lead, black, 12.5 cm (5") long, use with voltage / current outputs, 600 V, 32 Amps CAT II



**2008-539**  
**Sleeved Pair of Test Leads**



**83726**  
USB memory stick (1 each)



**Large test clip (1 each)**  
red, 40 mm opening



**640267**  
Large test clip (1 each)  
black, 40 mm opening



**1010-832**  
Hard-Sided transit case